

DETERMINATION OF MOISTURE DIFFUSION COEFFICIENT AND THERMO-GRADIENT COEFFICIENT IN SOME COLLOIDAL CAPILLARY-POROUS MATERIALS

V. P. Dushchenko and Kh. B. Baidzhanov

Inzhenerno-Fizicheskii Zhurnal, Vol. 9, No. 2, pp. 201-206, 1965

Results of determination of dependence of moisture diffusion coefficient and thermogradient coefficient of loams and Chasov Yar clay on moisture content at different dry densities are presented.

The experimental materials were four samples of loam from the Southern USSR (Askaniya Nova) taken at different depths from 1.4 to 6.4 m and Chasov-Yar clay (Table 1).

Table 1
Particle Size Distribution of Samples

Sample	Sampling depth, m	Particle distribution, %, by size, mm					
		0.25	0.25-0.05	0.05-0.01	0.01-0.005	0.005-0.001	0.001
Loam							
1	1.4-1.6	—	2.3	2.3	19.0	35.8	7.8
2	3.4-3.6	—	3.1	3.2	17.1	25.2	5.3
3	4.0-4.2	—	3.0	4.4	12.3	30.5	5.7
4	6.2-6.4	—	12.0	2.9	15.6	27.0	12.2
Chasov Yar clay	—	0.10	2.6	6.5	7.9	9.1	73.8

The differential water-retaining properties of the studied materials were determined by the drying thermogram method [1], heat of wetting [2], the indicator method of A. V. Dumanskii [3], and the sorption isotherm method (Table 2).

The moisture diffusion coefficient was determined by the convenient and simple method of steady-state moisture flow under isothermal conditions [4] using a simplified formula [5].

In [5] an experimental improvement based on apparatus similar to that of N. N. Bab'eva [6] was proposed. We followed up this proposal. The investigated (clays, soils, bentonites) and standard materials were placed in copper cylinders, diameter 36 mm. The open ends of the cylinders were closed by threaded caps. After this the cylinder, length 140 mm, was weighed on an ADV-200 M balance.

Table 2
Moisture Contents of Materials Investigated, %

Sample	Maximum hygroscopic moisture content from adsorption isotherms	Polymolecular adsorption moisture content			Molecular adsorption moisture content from 3rd critical point of thermogram
		From 2nd critical point on thermogram	From heat of wetting	From indicator method	
Loam					
1	11.8	5.6	4.7	—	3.6
2	11.1	5.2	4.6	—	3.2
3	12.1	5.5	4.7	—	3.4
4	11.6	5.1	4.5	—	3.2
Chasov Yar clay	16.6	7.7	6.62	7.1	3.3

Repeated experiments with different variations of the moisture contents of the materials studied and the standard most favorable for increasing moisture transfer through the interface and substitution of a photoelectric balance revealed that the proposed improvement is unsuitable, owing to the seriously underestimated sensitivity and reduced stability of the balance.

The given method is valid only for the short times ($F\sqrt{t} < 0.1$), for which the moisture contents of the materials remote from the interface remain constant and equal to the initial values. Therefore, during the experiment, it is important to verify that the moisture content at the ends of the contacting materials is constant. For this purpose, we used an electrical method for measuring the moisture content (conductimetric and capacitive).

The moisture diffusion coefficient was determined on the apparatus shown in Fig. 1, which consisted of aluminum or copper two-piece measuring cylinders, on the ends of which the moisture content detectors were mounted, a 465-kc discriminator (for capacity measurements), a slide wire bridge (for measuring the resistance of the moist material), a temperature-controlled chamber (for regulating the temperature of the investigated and standard materials), and an automatic electronic potentiometer (for recording the discriminator output voltage).

The measuring cylinder (Fig. 2) consists of two equal parts of length 50 mm and inside diameter 36 mm. The two parts are connected by a special threaded sleeve. The joint is recessed to take a rubber O-ring, which ensures a reliable waterproof seal.

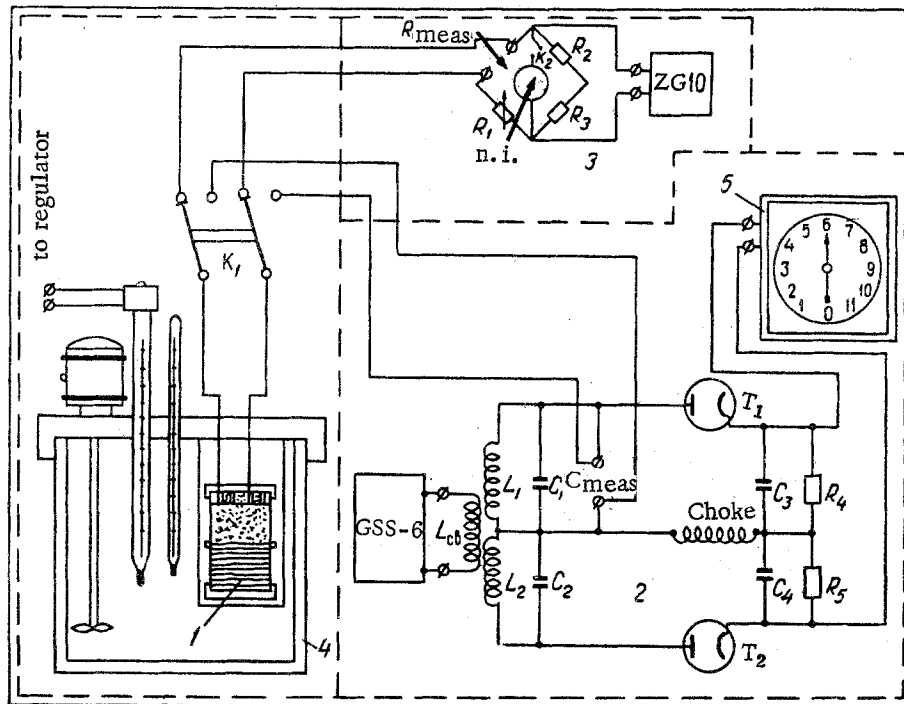

Fig. 1. Diagram of apparatus for determination of moisture diffusion coefficient: 1) measuring cylinder with moisture content detector; 2) discriminator; 3) slide-wire bridge; 4) temperature-controlled chamber; 5) automatic electronic potentiometer.

The ends of the cylinders are hermetically sealed by threaded caps with rubber gaskets. To ensure positive contact between the investigated and standard materials, a spring is included in the cap of the half-cylinder containing the standard (cellulose in the form of sheets of filter paper).

The electrodes of the moisture content detector were stainless-steel rings 12 mm high. The diameters of the outer ring were 32/28 mm, and of the inner, 11/8 mm. The outer ring was firmly inserted into a solid cylindrical ebonite receptacle, in the center of which a shaft was left to receive the inner ring. The assembled coaxial detector is mechanically strong. Between it and the bottom of the cap, a rubber gasket is introduced. The detector electrodes are independently led out to the measuring device through plug connectors on the side of the cap. The assembled detector, with cap, is screwed into the measuring cylinder.

After being filled with the investigated and standard materials, each at a predetermined density and moisture content, the two halves of the cylinder were weighed on a type ADV-200 M balance. They were then quickly coupled together by means of the sleeve. The assembled cylinder was placed in the temperature-controlled chamber and the moisture detector was connected to the measuring circuit. The constancy of the moisture content at the ends of the cylinder was checked up to a moisture content of approximately 15% by measuring the capacity, above 15% by measuring the resistance of the layer of moist material between the detector electrodes. The time during which these measured moisture contents remained constant served as a criterion for the duration of the experiment. In all experiments the moisture content of the standard material was in the range 1-3%.

After this, the cylinder was taken apart and the mass of each half was again determined separately. At the same time, a sample was taken for determination of the moisture content of the investigated and standard materials at the interface. Use of split cylinders made it easier to determine the mass of moisture diffusing through unit area of the interface, and is also more convenient from a practical standpoint.

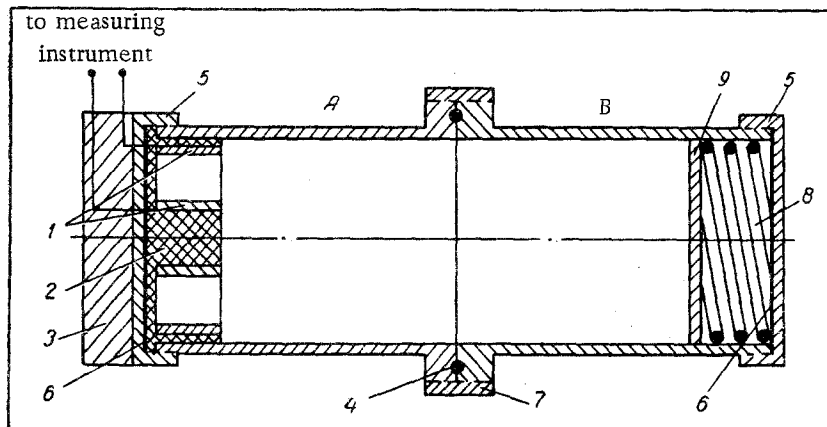

Fig. 2. Measuring cylinder: A and B) copper or aluminum cylinders for investigated and standard materials; 1) detector electrodes; 2) ebonite receptacle; 3) plexiglass base; 4) rubber O-ring; 5) threaded cap; 6) flat rubber gasket; 7) threaded sleeve; 8) spring; 9) plexiglass plate.

Experimental data on one of the loams and Chasov Yar clay, measured at 20° C, are given in Fig. 3.* (For the remaining loams the trend of the curves was similar.)

It is seen from the figure that at small moisture contents (corresponding approximately to the moisture content of monomolecular adsorption), moisture transport takes place by diffusion in the vapor phase. In this case a_m increases. With increase in the moisture content of the material up to the maximum hygroscopic value the fraction of moisture transported in liquid form increases. Liquid migrates not only under the influence of capillary forces through the complex capillary system, but also by selective diffusion through the permeable walls of the soil particles. The rate of this diffusion transport of liquid is significantly lower than the rate of molecular movement of liquid under the action of the capillary potential. It is obvious that, in this case, the first form of transport is predominant, which also leads to a decrease in a_m with increase in moisture content up to the maximum hygroscopic moisture content for loams, and the moisture content of polymolecular adsorption for Chasov Yar clay.

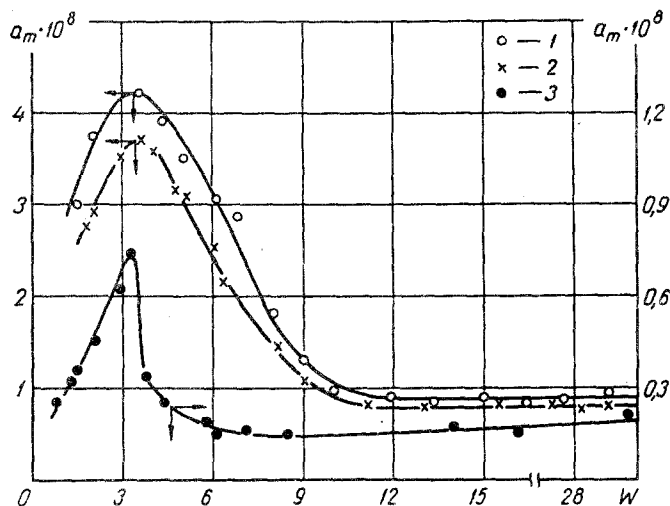

Fig. 3. Dependence of diffusion coefficient a_m (m^2/sec) on moisture content of material W (%): 1, 2) loam 1 ($\gamma_0 = 1200$ and 1450 kg/m^3); 3) Chasov Yar clay ($\gamma_0 = 1140$ kg/m^3).

The constancy of a_m in the region of moisture contents greater than the maximum hygroscopic value for loams and polymolecular adsorption for Chasov Yar clay (which has been noted in a number of papers [8, 9, 10]) can obviously be explained in this case by the fact that moisture transport takes place only in the liquid phase through the capillary-

* In general form the curves $a_m = f(W)$ are similar to those for typical colloidal substances in [7].

porous system of the solid. The constancy of a_m in this moisture content region significantly simplifies the problem of calculating the moisture flow and moisture field by analytic methods.

The coefficient a_m for the investigated loams and Chasov Yar clay changes little with variation of the density of the dry material in the range up to 2000 kg/m^3 .

The dependence of the thermogradient coefficient δ of the materials studied on their moisture content at different densities of the dry material γ_0 was determined by the steady-state method previously described in [11] (Fig. 4). This method in various forms has been widely used for mass measurements [4, 7, 8, 12].

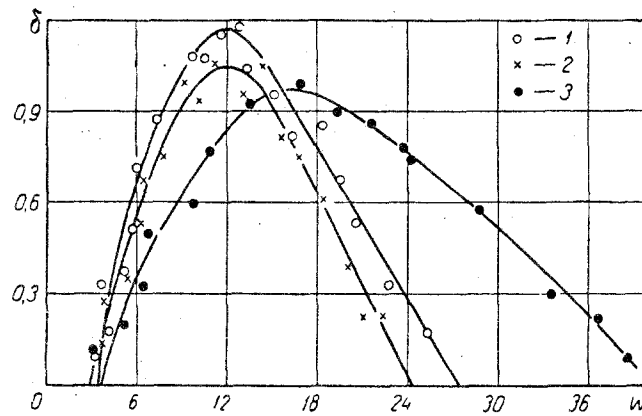

Fig. 4. Dependence of thermogradient coefficient δ ($\%/ \text{deg}$) on moisture content of material W ($\%$): 1 and 2) loam 1 ($\gamma_0 = 1200 \text{ kg/m}^3$; $t_h = 45^\circ \text{C}$; $t_c = 3^\circ \text{C}$ and 1450); 3) Chasov Yar clay ($\gamma_0 = 1140 \text{ Kg/m}^3$; $t_h = 96^\circ \text{C}$; $t_c = 6^\circ \text{C}$).

It follows from analysis of the curves $\delta = f(W)$ that the moisture of monomolecular adsorption is nonthermoactive ($\delta = 0$). Up to these moisture contents heat transfer is realized by conduction. Subsequently, the thermogradient coefficients of the loams and Chasov Yar clay, typical colloidal capillary-porous materials, increases with increase in moisture content, because of condensation at cold spots of vapor migrating by effusion, and movement of moisture in liquid form in the direction of heat flow under the action of entrapped air. The maximum of the curves $\delta = f(W)$ corresponds roughly to the boundary of maximum hygroscopic moisture content. Subsequent increase in moisture content leads to gradual obstruction of the water-bearing pores with moisture, including condensate. Diffusion of free water takes place mainly by selective diffusion. The thermogradient coefficient for selective diffusion is very small and with further increase in moisture content it decreases. Increase in the density of the dry material leads to a small decrease in the value of the thermogradient coefficient. For transitions of this kind in the high-density region this decrease is smaller in magnitude.

NOTATION

W —moisture content of material; a_m —moisture diffusion coefficient; δ —thermogradient coefficient; γ_0 —density of dry material; t_m —mean temperature of material; t_h —temperature of hot end of material; t_c —temperature of cold end of material.

REFERENCES

1. M. F. Kazanskii, DAN SSSR, 103, 5, 1960.
2. F. D. Ovcharenko, The Hydrophilic Nature of Clays and Clay Materials [in Russian], Izd. AN USSR, 1961.
3. A. V. Dumanskii, The Lyophilic Nature of Disperse Systems [in Russian], Izd. AN USSR, 1960.
4. A. V. Lykov, Transport Phenomena in Capillary-Porous Solids [in Russian], GITTL, 1954.
5. V. D. Ermolenko, IFZh, no. 8, 1960.
6. N. N. Bab'ev, Tr. MTIPP, no. 6, 1956.
7. A. V. Lykov, Theory of Drying [in Russian], Gosenergoizdat, 1950.
8. A. V. Lykov, Heat and Mass Transfer in Drying Processes [in Russian], Gosenergoizdat, 1956.
9. A. V. Lykov, Kolloidnyi zhurnal, no. 2, 1947.
10. Ya. M. Miniovich, Supplement IV to the book by M. Girsh, Drying Technology [in Russian], ONTI, 1937.
11. F. L. Giterman and V. P. Dushchenko, collection: New Physical Methods for Processing of Foods [in Russian], GITL UkrSSR, 1963.
12. A. V. Kukushkin, IFZh, no. 6, 1960.